

Best practises in utilizing Industry 4.0 principles

Tallinn, May 12th 2015

Dipl.-Ing. Fabian Quint

German Research Center for Artificial Intelligence, DFKI GmbH
Researcher and Head of the section “Humans and Technology”

- **The SmartFactory^{KL}**
- Introduction
- Industrie 4.0 paradigms showcased
- Conclusion

The SmartFactory^{KL}



Application



Industry



Manufacturer

Academia



The SmartFactory^{KL}

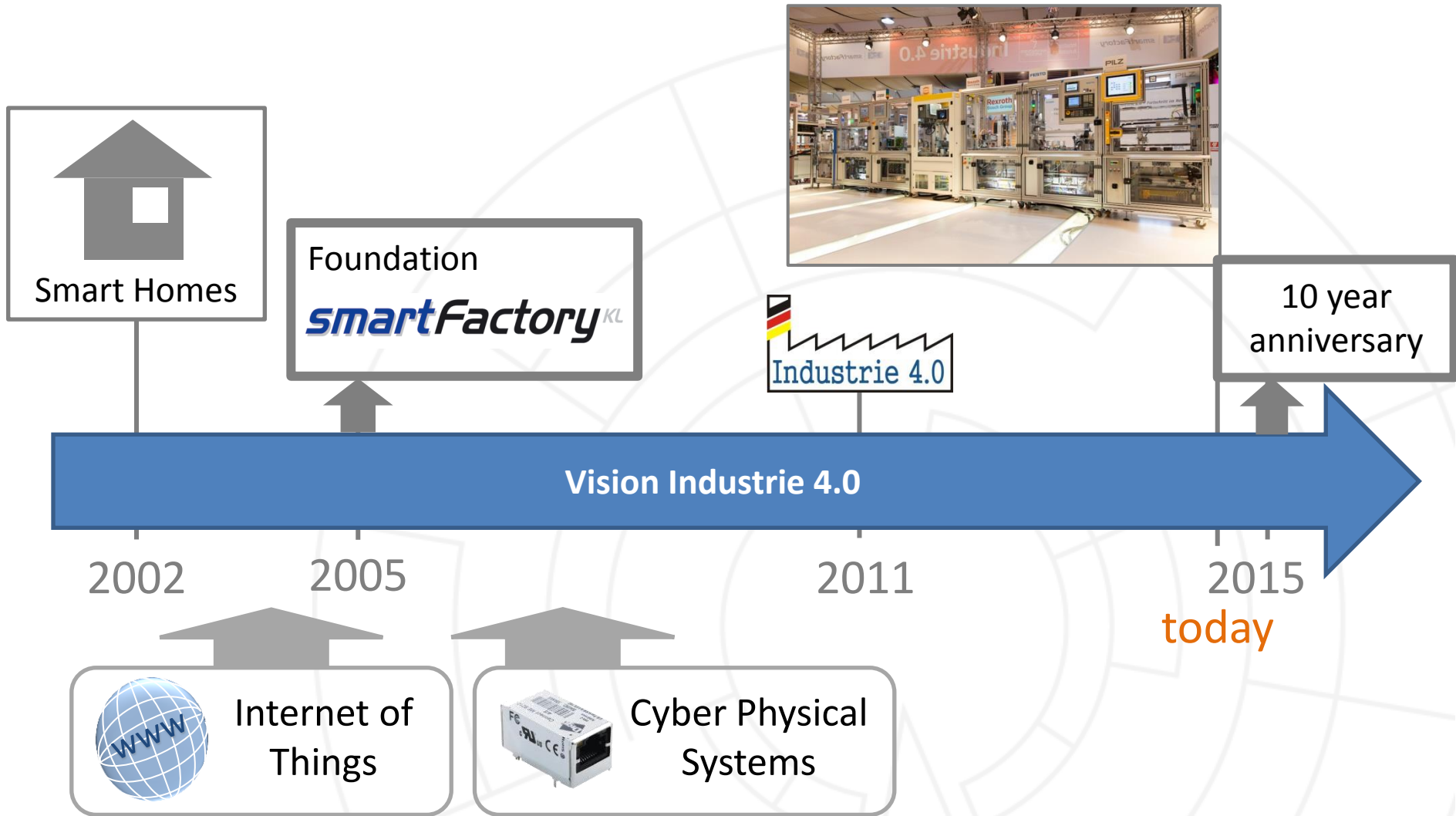

- **The SmartFactoryKL**
- **Introduction**
- **Industrie 4.0 paradigms showcased**
- **Conclusion**

Industrie 4.0

Means linking all factory objects into a network based on Internet technologies

In consequence all objects like machines, products but also humans are smart elements in a production process.

the smart planner

the smart workpiece

the smart machine

the smart operator

The Smart Machine

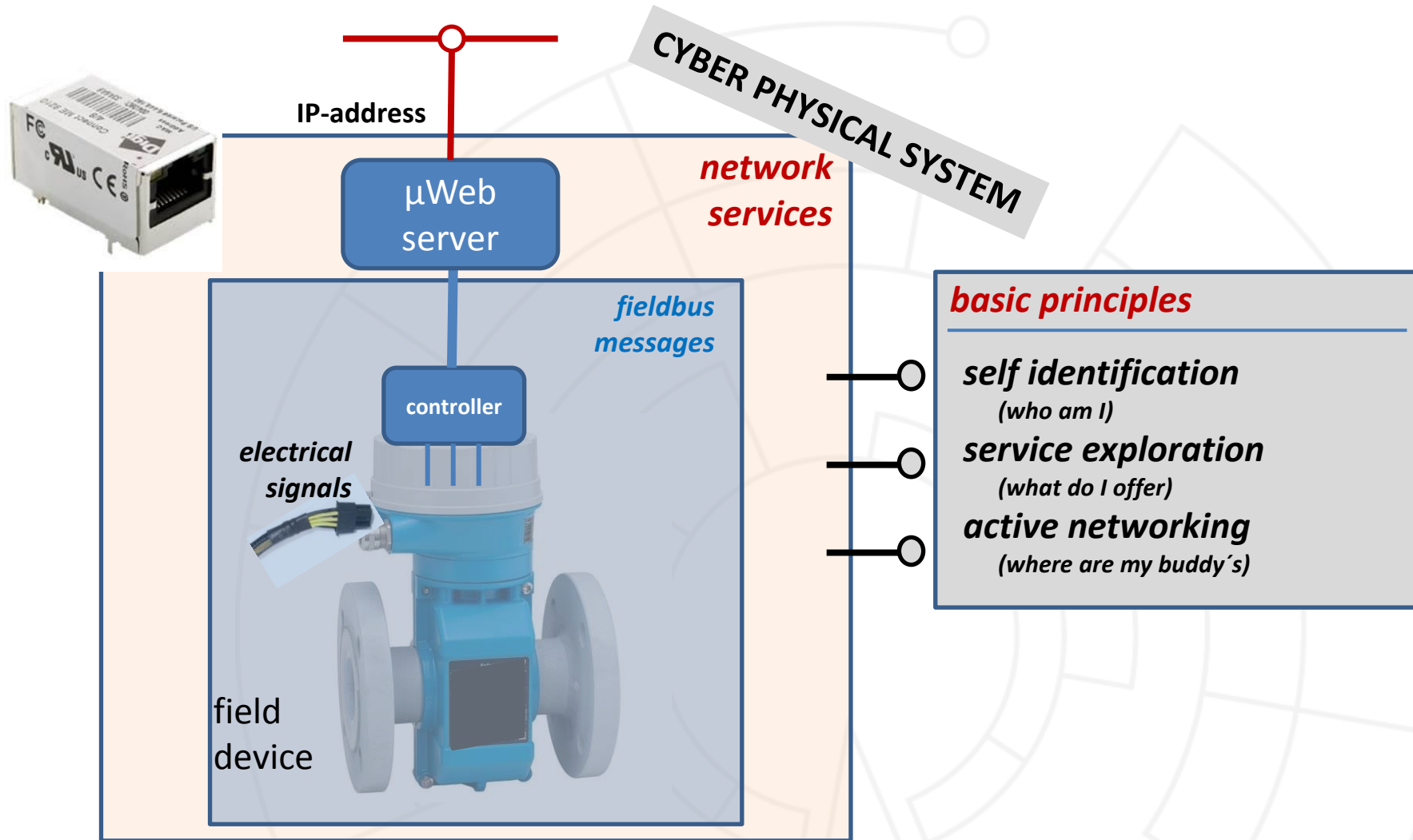

The Smart Machine

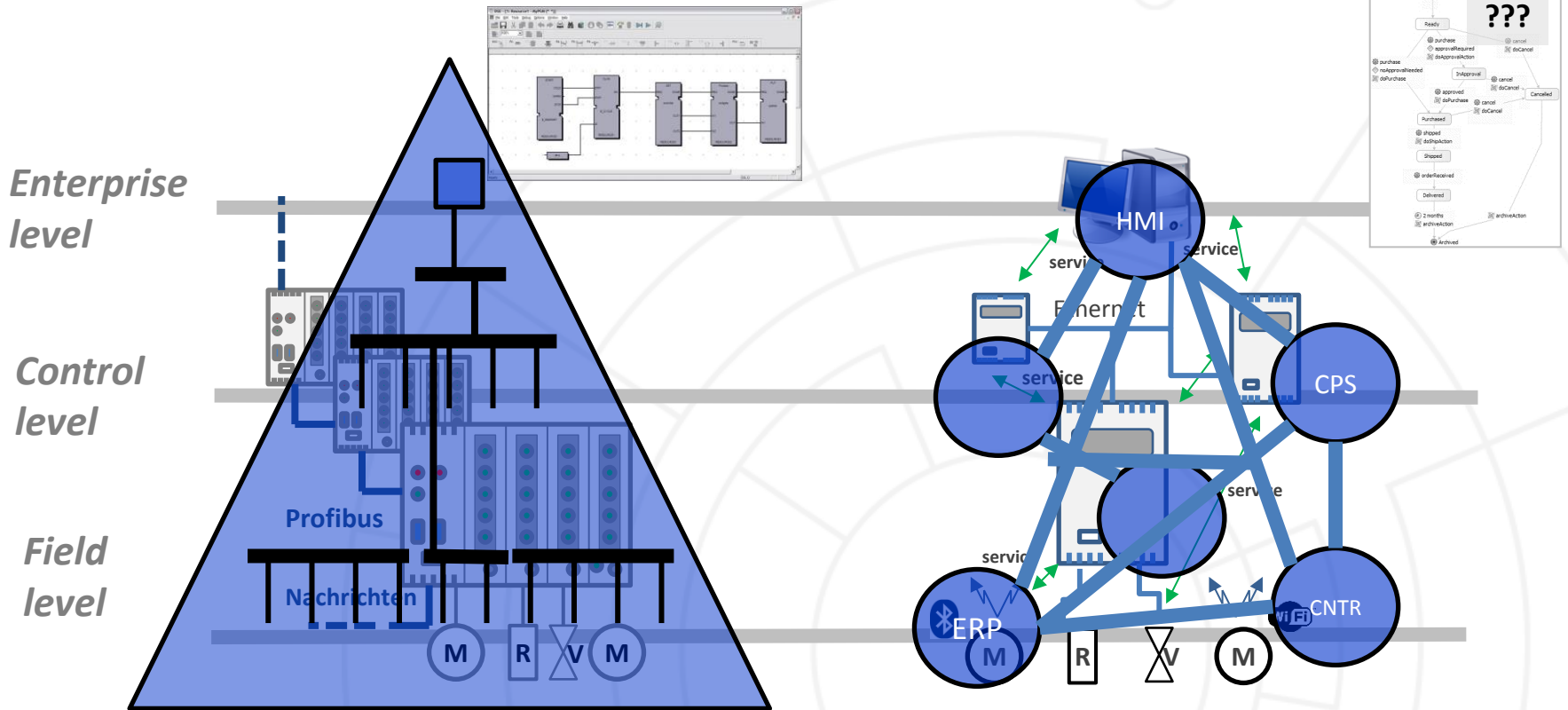

Today
Tomorrow

Hierarchical Automation
Smart CPS Network

- The SmartFactoryKL
- Introduction
- **Industrie 4.0 paradigms showcased**
- Conclusion

Demonstrator ResCom

2011

Completely controlled by a CPS based network

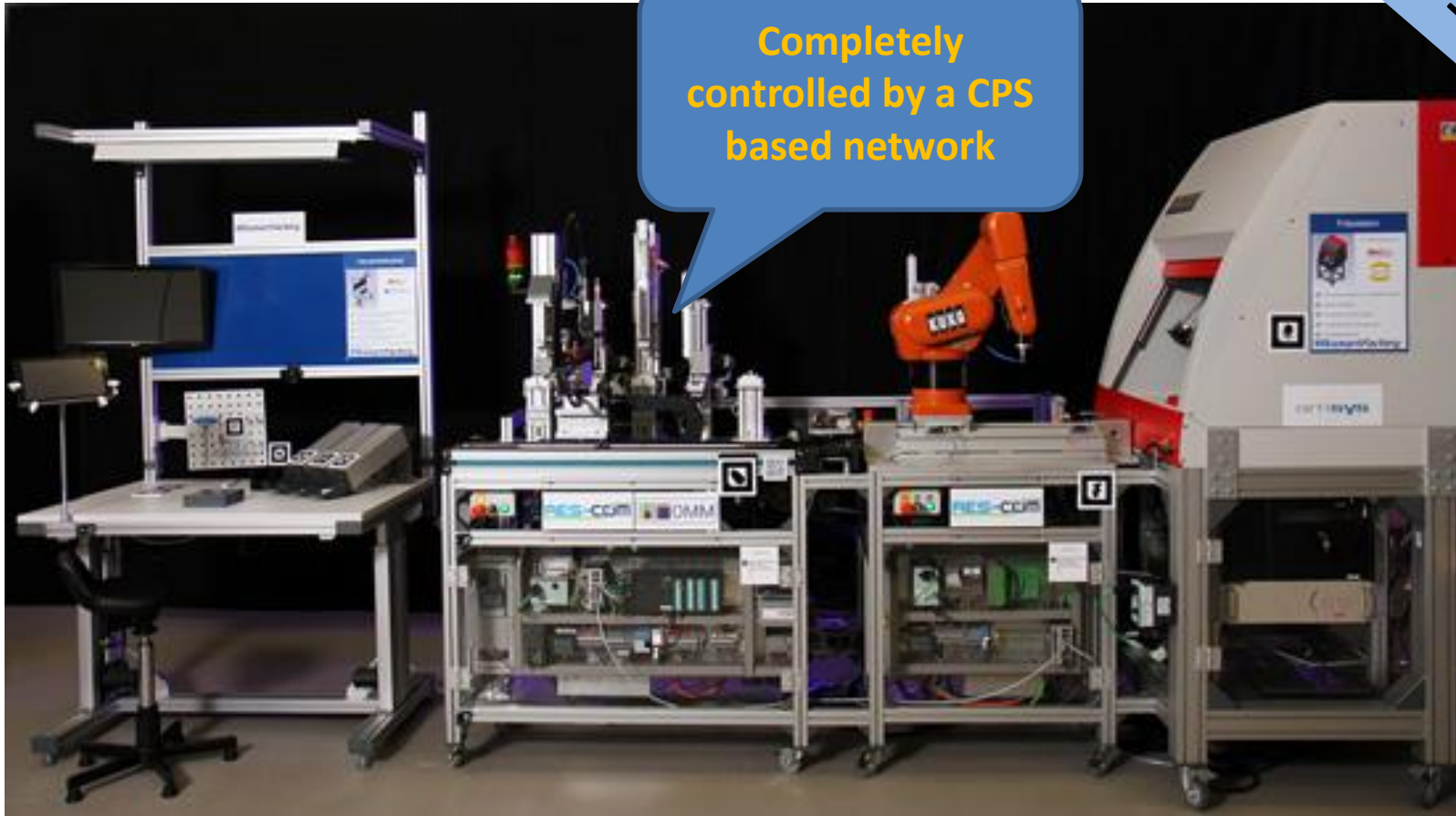

Manual Workstation

Product Assembly

Product Handling

Engraving

CPS Production Demonstrator

2011

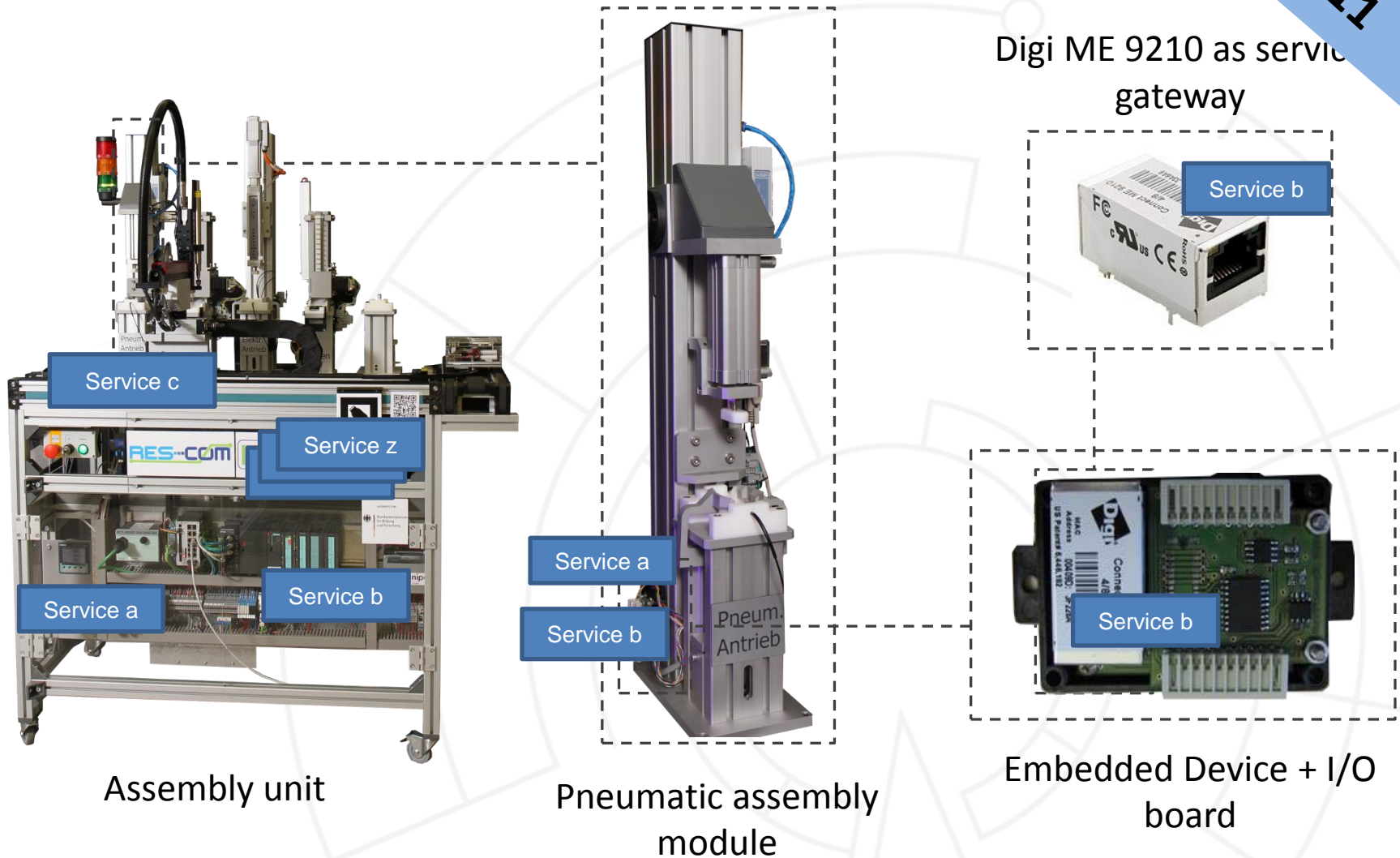

Service-orientated Control Architecture

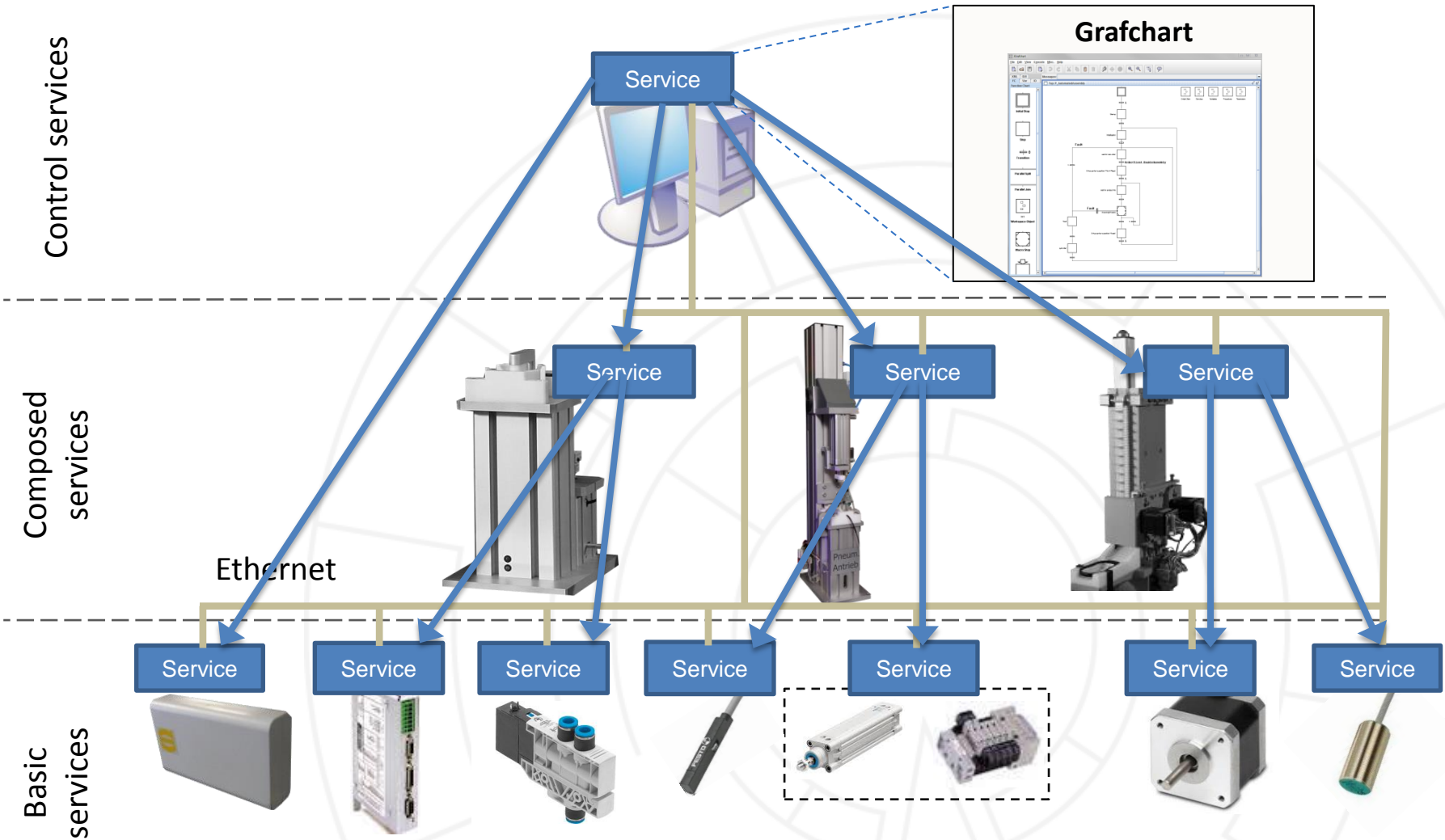

Worlds' first Industrie 4.0 Demonstrator

2014 & 2015



Security



Monitoring



ERP



PLM



Worlds' first *Industrie 4.0* Demonstrator



Plug 'n Produce scenario

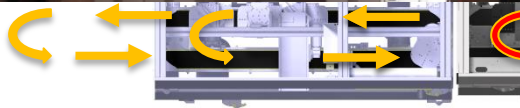
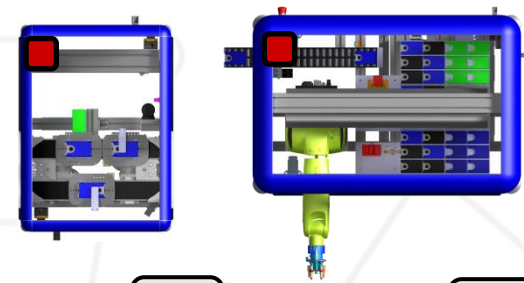
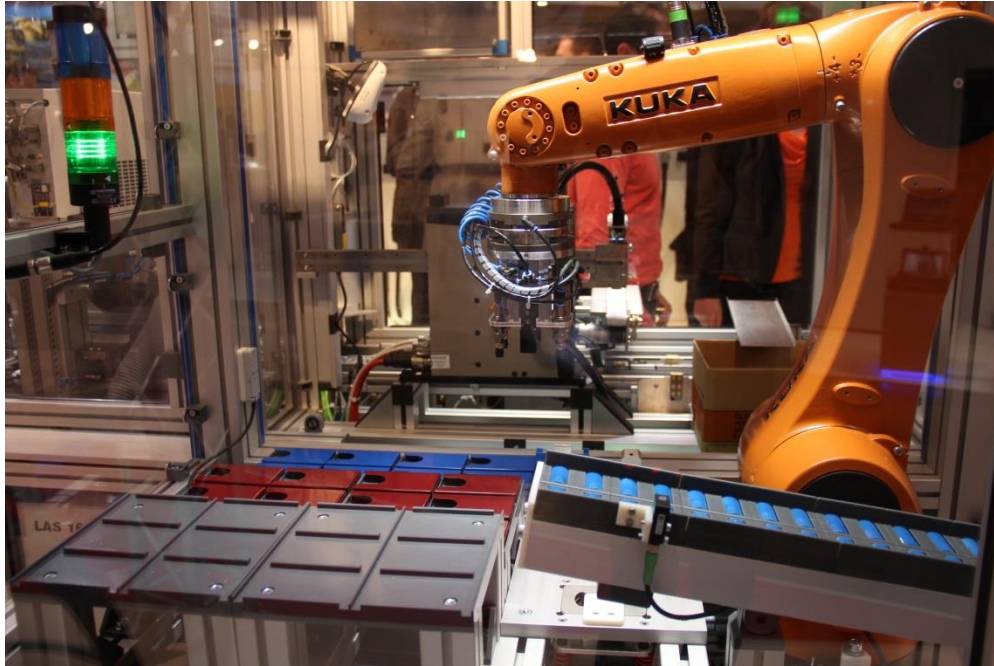

quality control scale laser

Product:



Enabling Technologies

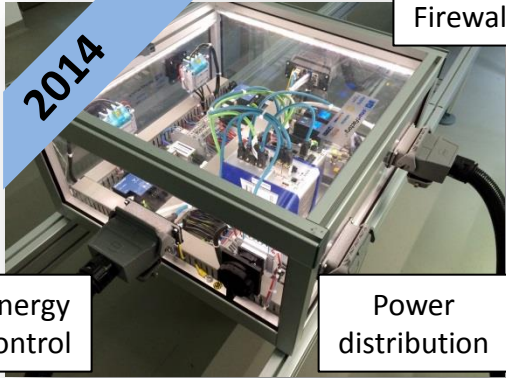

Energy control

Power distribution

Firewall

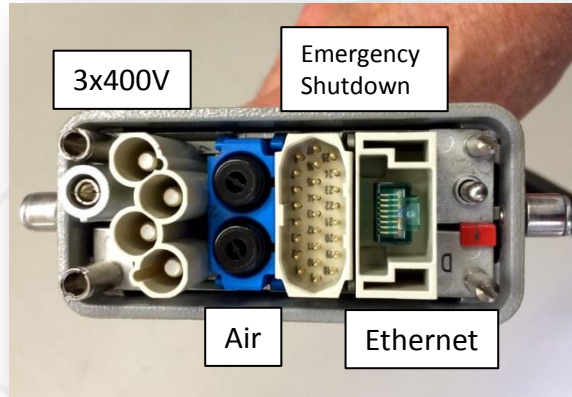

3x400V

Emergency Shutdown

Air

Ethernet

Our „USB connector“

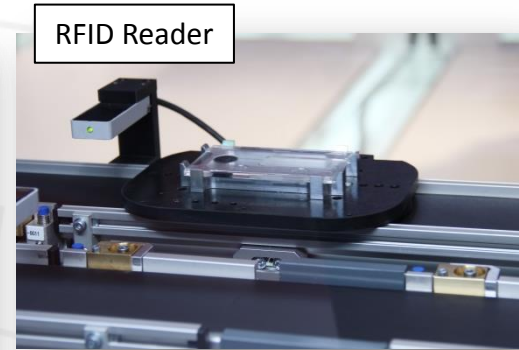

RFID Reader



Infrastructure Boxes



Neighbor Detection

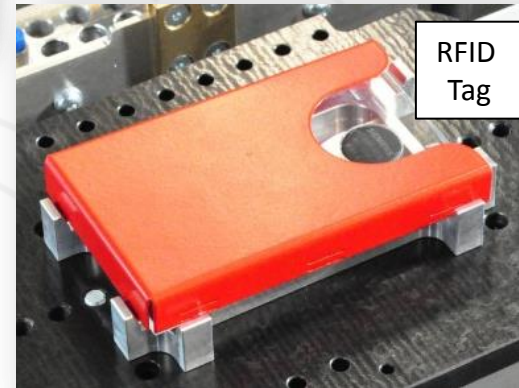

RFID Tag

Digital Product Memory

Standards are Available

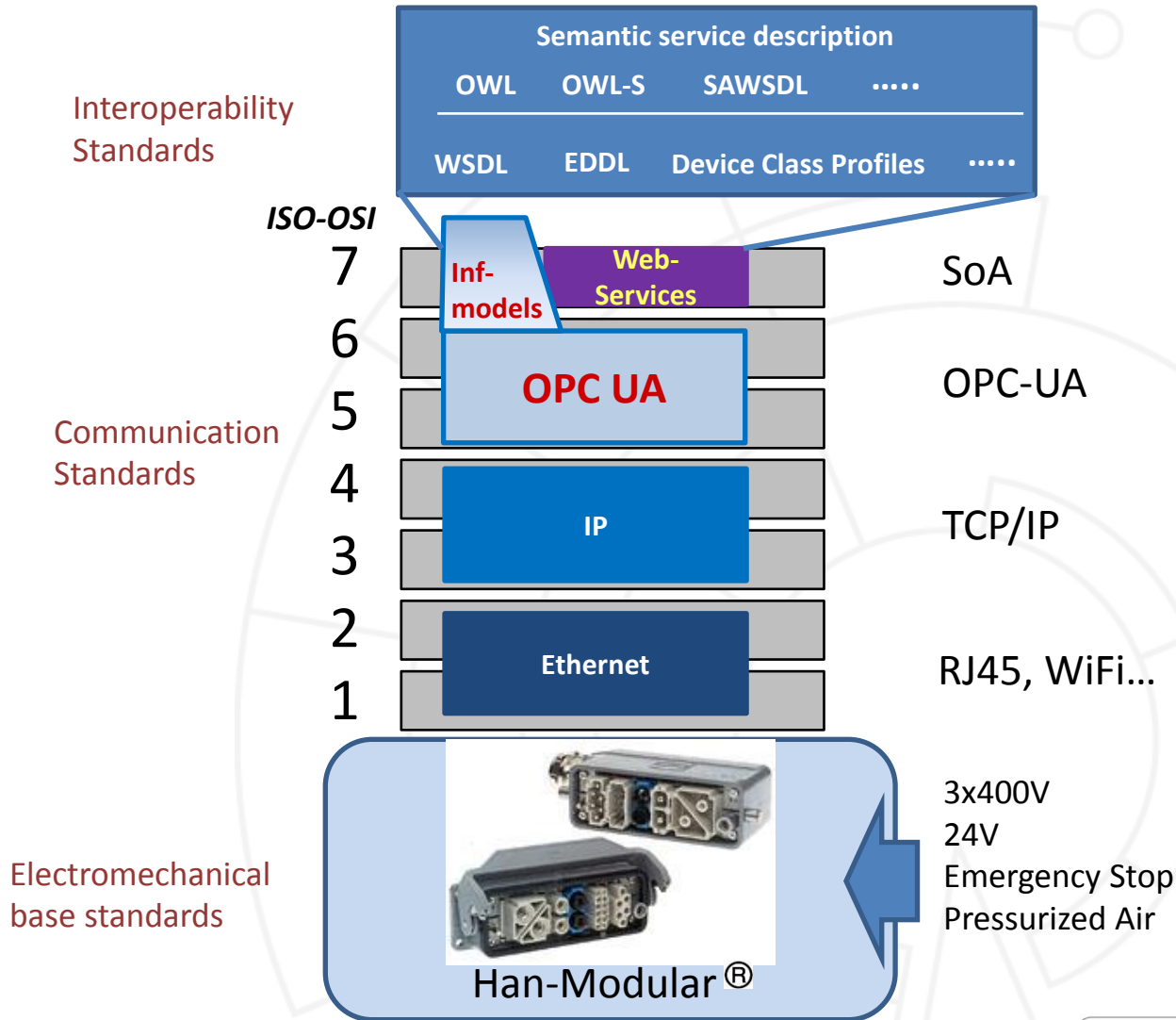

From Smart Objects to Smart Factories

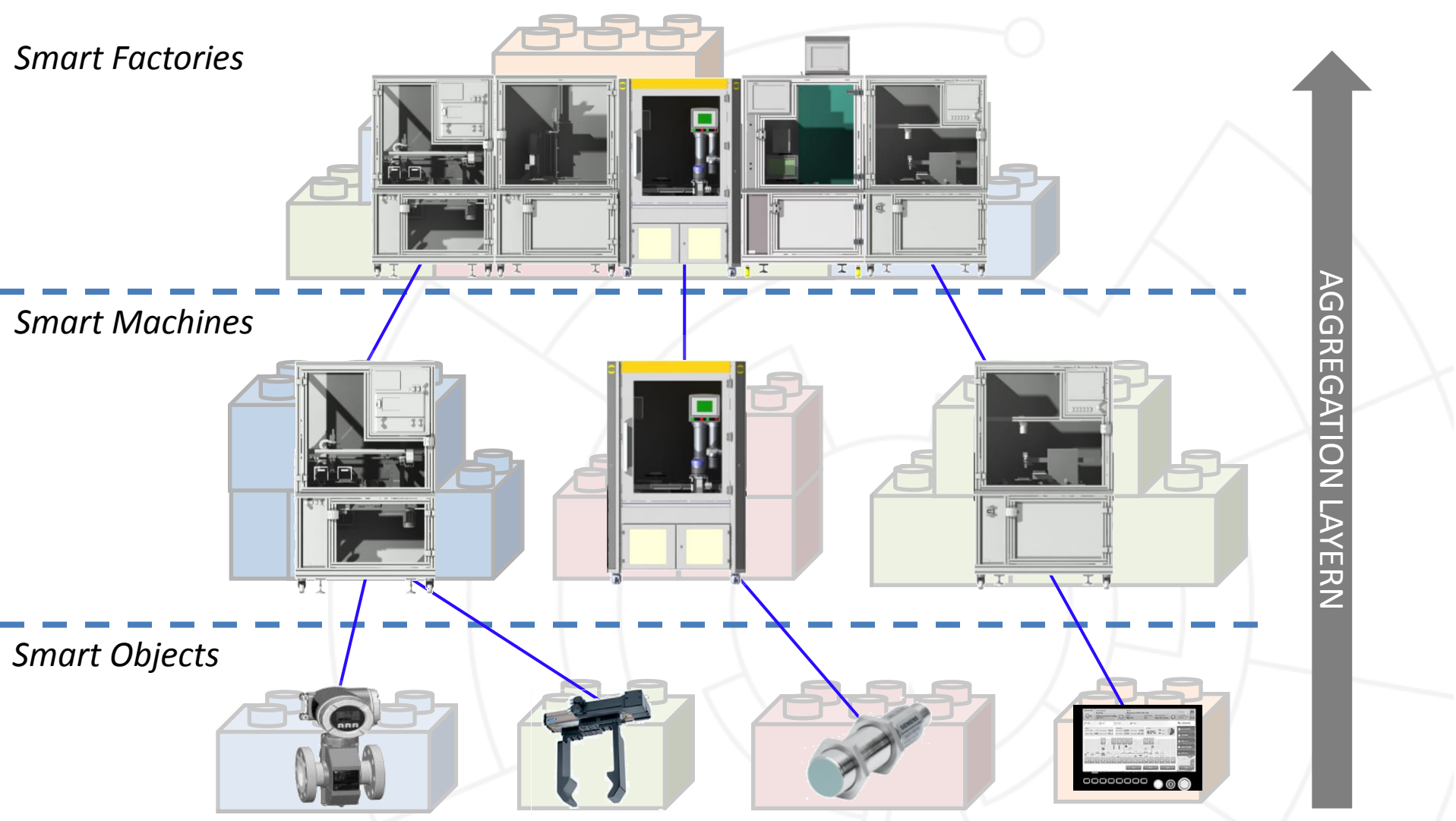

Smart Operator

How can consumer interaction technologies be used to serve the future worker in an efficient way?



Smart Operator

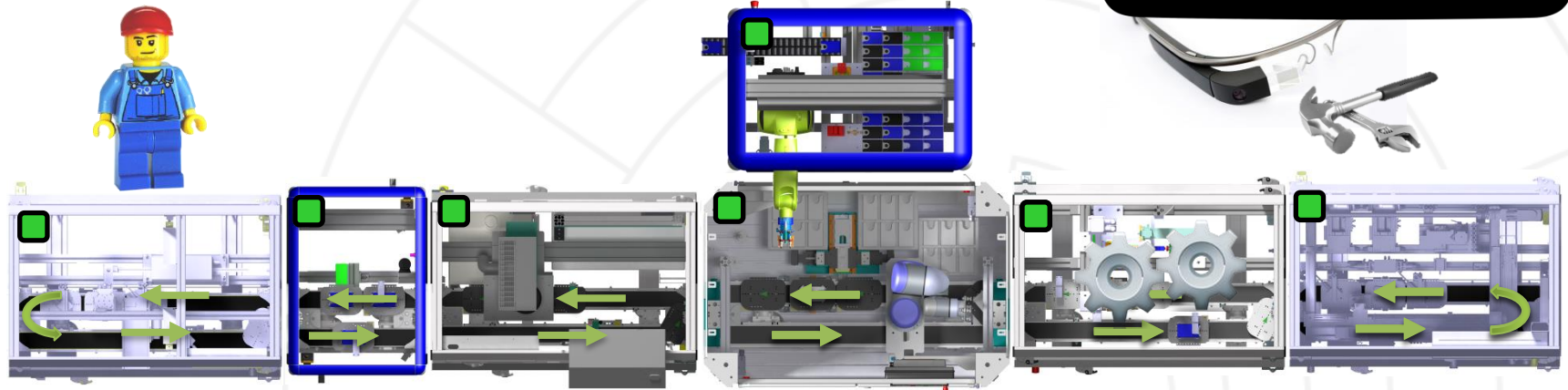
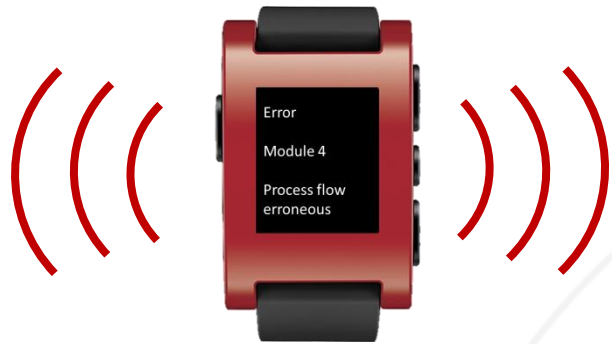

Error: Process flow erroneous

Caused by RFID reader malfunction

Smart Operator



Augmented.smartFactory SmartModule Information

Engraving Module - Festo

FESTO

- Summary
- Components
- Troubleshooting

- ✓ Festo Gabellichtschranke
- ✓ Rotating device for the engraved casing bottom
- ✓ CoDeSys-Controller (Effectuator)
- ✓ Workpiece magazines with controller

Festo Gabellichtschranke Troubleshooting ▶ Start Steps

Light barrier detects the presence of glass base in the module

1. Check for correct placement of glass base
2. Check if the orange LED illuminates to indicate detection of glass base. If the problem persists proceed to next step.
3. Unscrew the screws as shown.
4. Remove connector as shown.
5. Place connector as shown.
6. Screw the screws as shown.

Manual Workstation



- The SmartFactoryKL
- Introduction
- Industrie 4.0 paradigms showcased
- Conclusion

The Rocky Road to Industrie 4.0

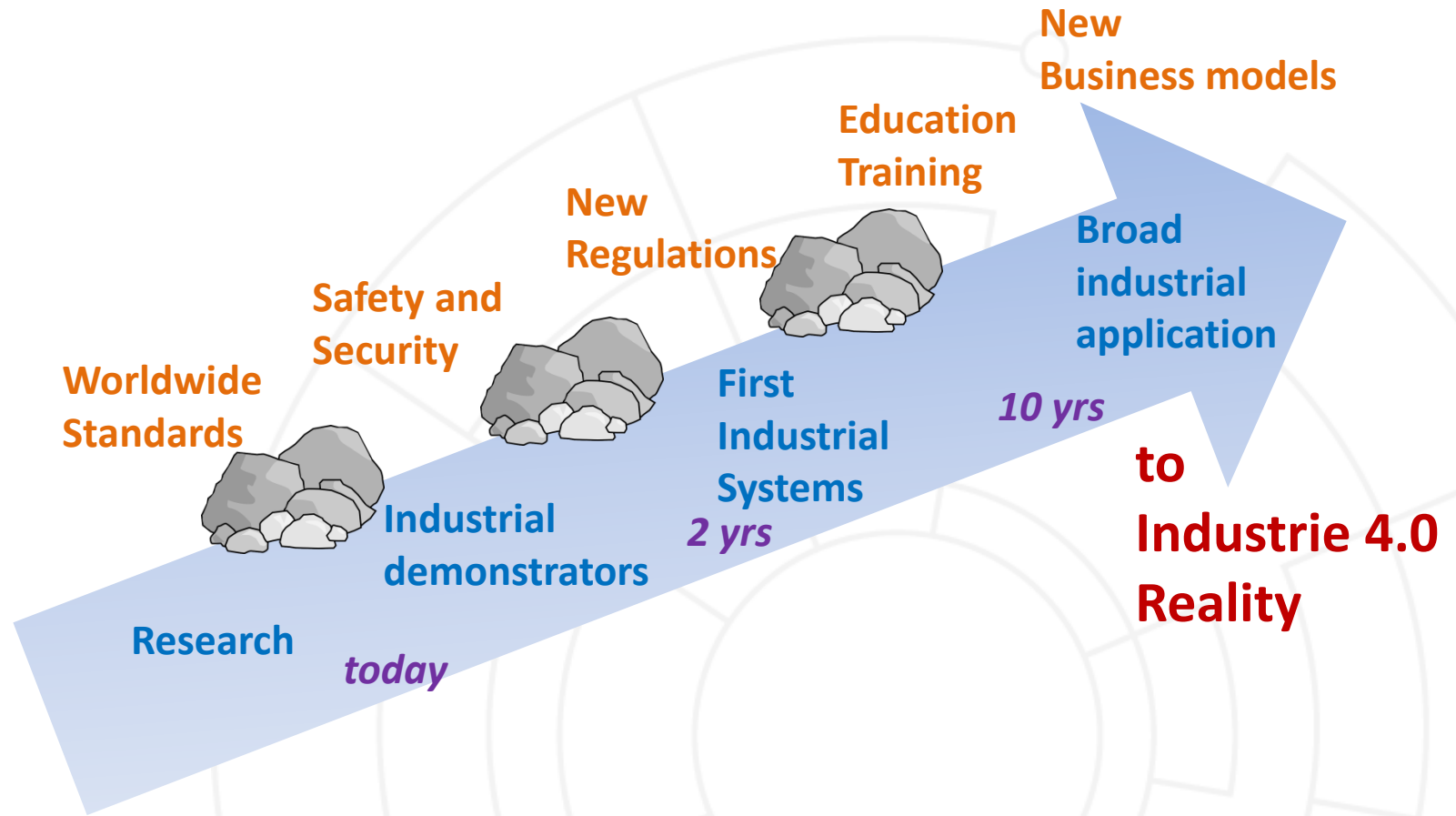

from
Industrie 4.0
Vision

THANK YOU FOR YOUR ATTENTION!

Fabian Quint
Innovative Factory Systems
German Research Center for
Artificial Intelligence DFKI-IFS
Trippstadter Str. 122
67663 Kaiserslautern
Tel: +49-631-20575 5019
Fabian.quint@dfki.de

